

SPECIFICATIONS & TECHNICAL CHARACTERISTICS

DESCRIPTION	DETAILS
Body type	Hardtop
Body material	Steel (frame and bottom, hot dripped galvanized) and aluminum (cabin)
Steering	Skid steering
Tire size	1800x600x25 (72x23x25in)
Types of tyres	Tubeless, extra-low pressure
Suspension	Pneumatic circulating
Maximum speed (at the top-gear)	Up to 40 km/h (25 mph)
Minimum speed (at the low-gear)	2 km/h (1.2 mph)
Engine model	Hyundai Infracore (Formerly Doosan)
Fuel type	Diesel
Emission control	Stage 5 / Tier-4-final
Engine doc (Diesel Oxidation Catalyst)	DOC+DPF/DOC only
Fuel consumption	5 - 8 l/h
Engine displacement	1.8 L
Cylinder count	3

DESCRIPTION	DETAILS
Max engine power	41 kW (55 hp)
Max engine torque	190 nm
Generator performance	140 A
Fuel tank volume	95 L
Capacity of additional fuel canisters	4 x 58 L
Gearbox	Mechanical, 6-speed
Dry weight	2400 kg
Loading capacity	Up to 1200 kg
Towing capacity	2350 kg
Cabin internal volume	2 cu m
Rear space internal volume	5.8 cu m
Overall internal volume	7.8 cu m
Maintenance interval	250 hours (first 50 hours)
Parking brake system	Mechanical handbrake
Ground Clearance	550 mm

JSW Gecko Motors

SPECIALIST MOBILITY VEHICLE

SMV N1200 ATOR



Dashboard

Rear Cabin with Seats

Cargo Variant

JSW Gecko Motors

JSW Gecko Motors Private Limited

83, Industrial Area, Phase 1, Chandigarh -160002

Website: www.jswgeckomotors.com

Email : jsw.geckomotors@jsw.in

Contact: +91 82839 99096

Follow us on Social Media



The Ultimate All Terrain Off Roader

A JSW Defence Initiative

SMV N1200 ATOR

The **SPECIALIST MOBILITY VEHICLE SMV N1200 ATOR** is an amphibious all-terrain vehicle engineered to improve mobility, increase operational effectiveness, and guarantee safety across various environments. It delivers exceptional performance in difficult terrains, showcasing an impressive ability to overcome obstacles, transition smoothly from water to land, and break through ice.

WE REACH WHERE FEW DARE

- Extreme Terrain
- Extreme Weather
- Extreme Mobility

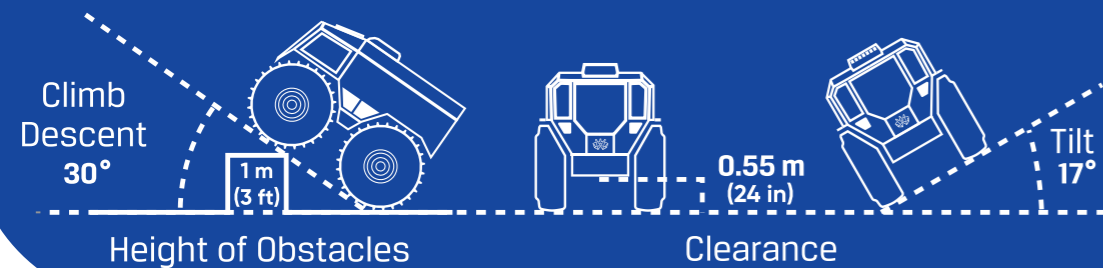

Overall Dimension

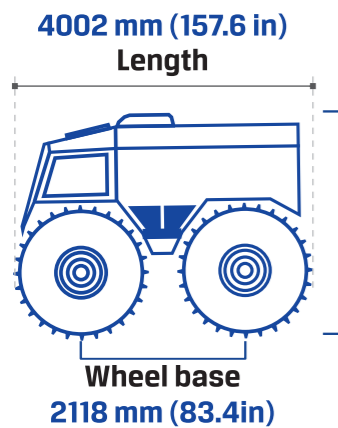

Height without AC
2825.5mm (112.3 in)

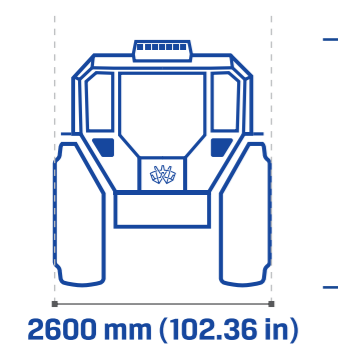

Service Temperature

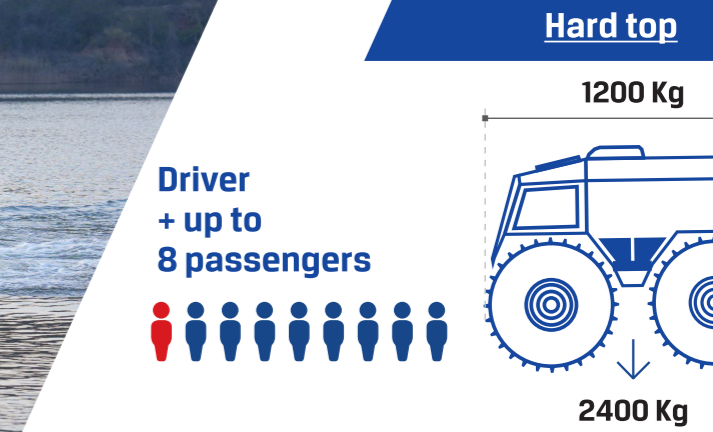
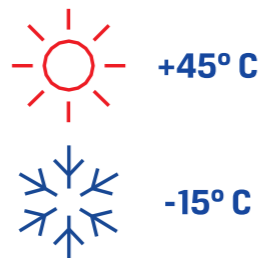

Base Model Includes:

- Front cabin
- Rear compartment ROPS
- Rear view camera
- LED high & low beam
- Towing hitch integrated in front & rear bumpers
- Integrated front & rear door ladder
- Parking brake
- 2 Seats in front cabin with 3 Point seat belt (driver & co passenger)
- Glove boxes & cup holders
- Under floor storage boxes
- Additional fuel canister in each wheel
- A/C
- Preparation for winch set
- Foldable 7 rear seats with 3 point seat belt
- Side windows 2
- Side mirrors 2
- Autonomous heater
- Backup battery
- Interior fabric cover

Additional Options

- Rear seats 2 or 4 with seat belt
- Winch set
- Front LED roof light bar
- Locker (2)
- Overhead locker (4)
- Set of cargo storage nets
- Side windows 4
- Universal trailer
- Interior cover eco leather
- Interior cover suede leather
- Spare wheel kit (Tire 1800 mm, disc, badlock & bolt) (1 each in 1 set)

Max. Speed

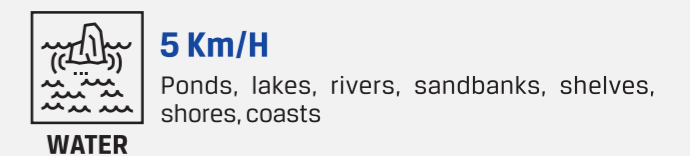
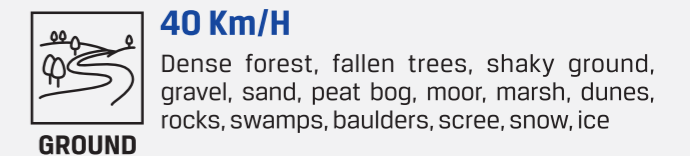

Fuel Autonomy

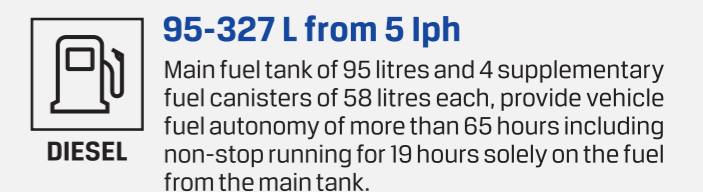

SMV N1200 ATOR AMBULANCE VERSION



INTERIOR

A JSW Defence Initiative

LIST OF EQUIPMENTS INSIDE AMBULANCE - CRITICAL CARE

- Multi Para Monitor Model (Equipment for monitoring Vitals like Bp, heart rate, oxygen levels etc)
- Foldable stretcher
- Scoop Stretcher
- Pneumatic Transport Ventilator Military Standard
- Automatic Defibrillator
- Nebulizer
- Syringe pump Military Standard
- Emergency Kit for Life support system
- Spine board with head lock
- Portable Suction Machine AC/DC
- Set of 6 Pneumatic splints
- Cervical collar - 1 Adult & 1 Kids
- Fire Extinguisher
- Oxygen Cylinder
- Oxygen Concentrator
- Storages for medicines, injections etc, optional tools for medical procedure, blankets, gloves, safety shoes, dressings, bandages, safety helmet, shovel, hammer, protective clothes etc. based on need of end user
- Oxygen outlets
- Electric points



ACCESSORIES RACK



MONITOR

SYRINGE PUMP

VENTILATOR

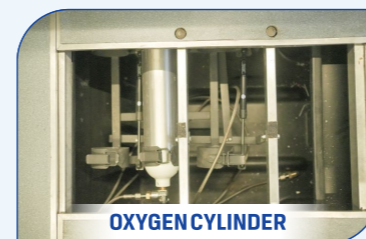

OXYGEN CYLINDER



AUTOMATED EXTERNAL DEFIBRILLATOR



SUCTION PUMP



STRETCHER